

# Cartas ASM

FCHE2011

## Componentes:

- Cajas de Estados: permanece en este por un ciclo de reloj.

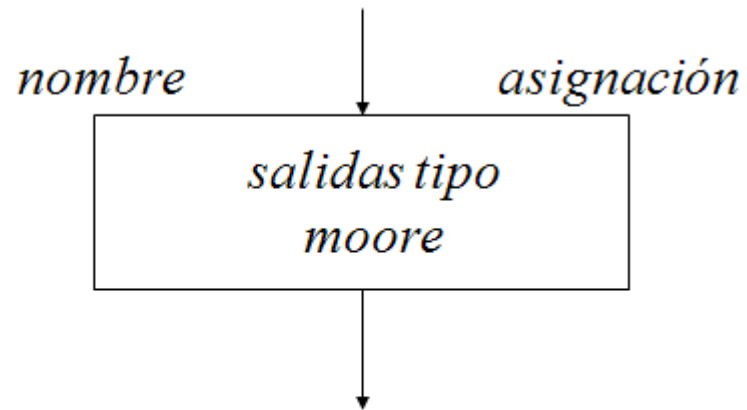

*Ejemplo:*

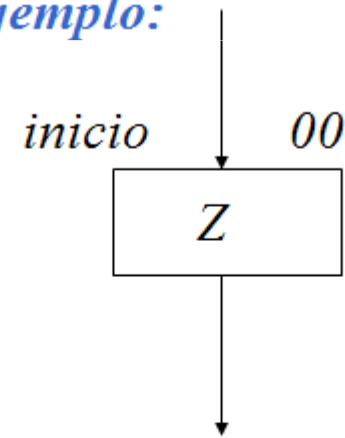

# Componentes

- Cajas de Decisión: se chequean luego de transcurrido el pulso de reloj.

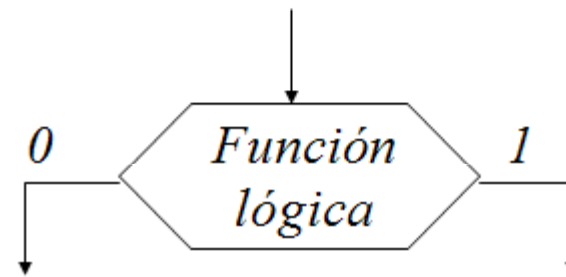
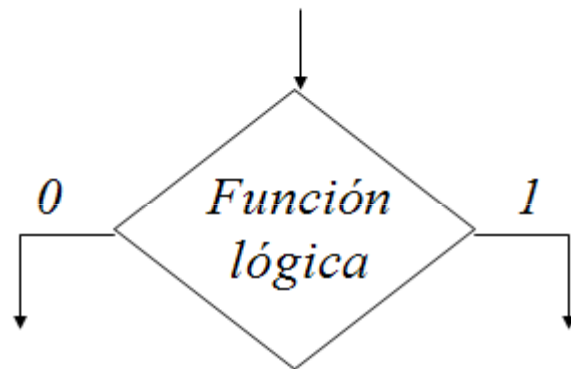

*Ejemplos:*

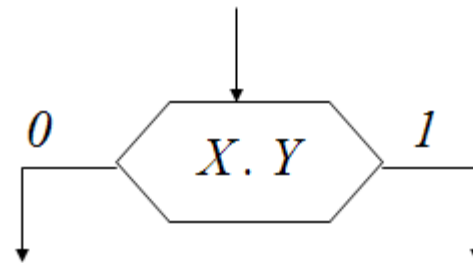
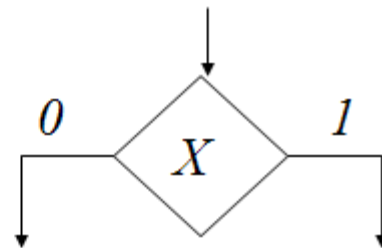

# Componentes

- Salidas tipo mealy: se generan luego de una caja de decisión.

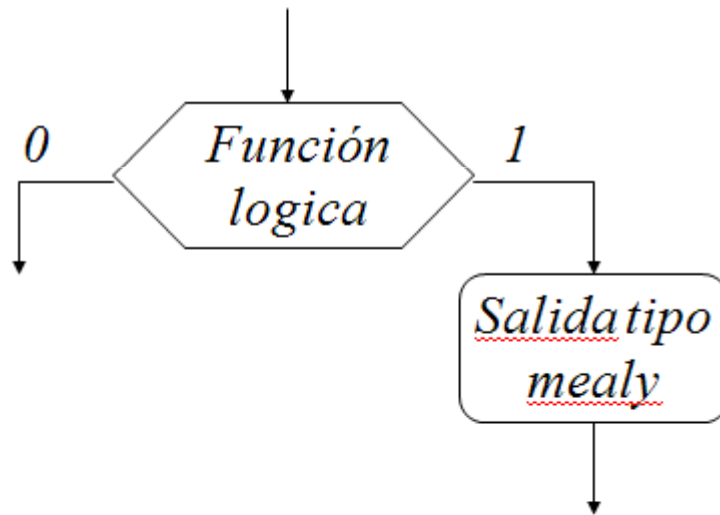

*Ejemplo:*

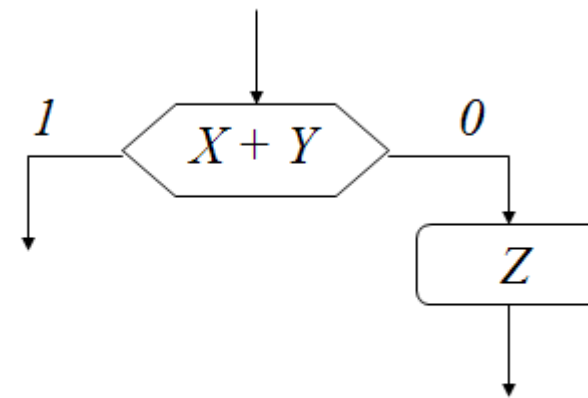

# Maquinas de Estado Algorítmico ASM

ASM



Indica el inicio

**Estable**

Condicional sobre G

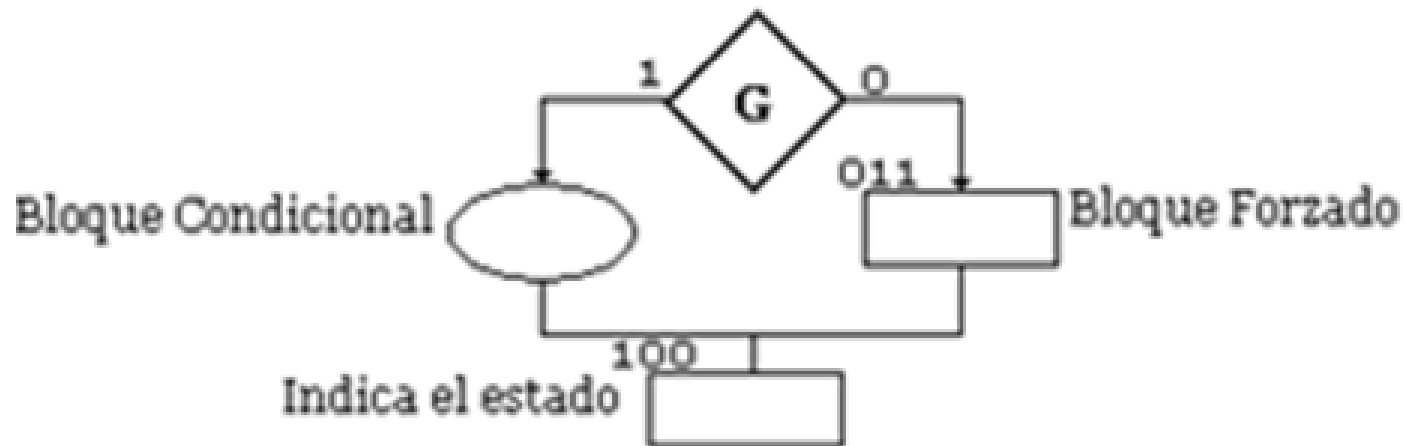

# Tipos:

## ASM del modelo de Mealy

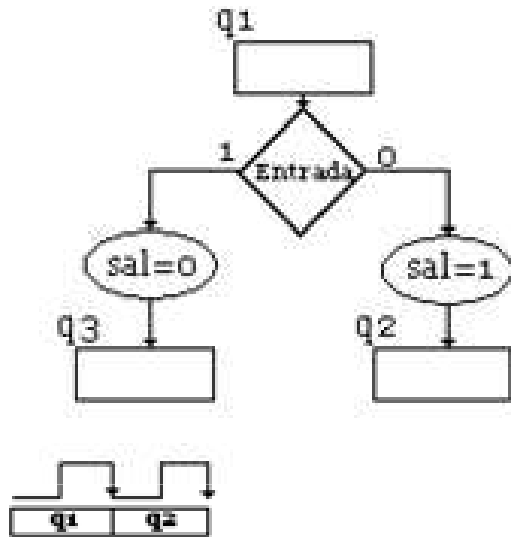

## ASM del modelo de Moore

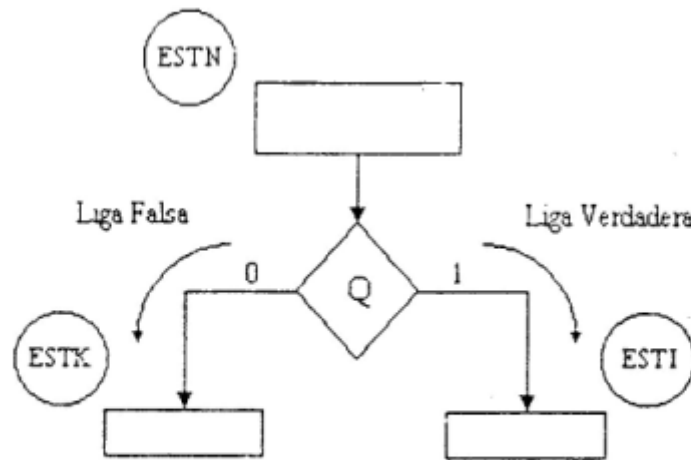
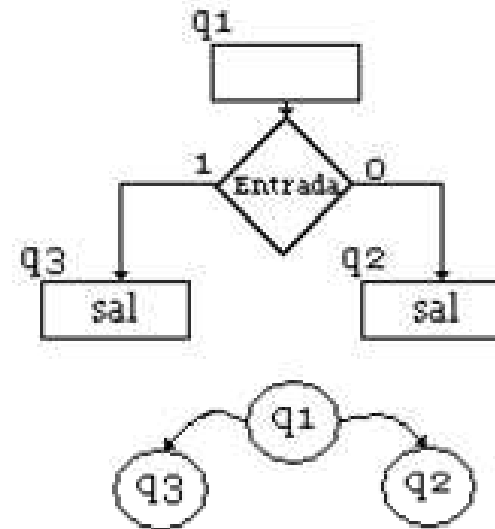

La liga falsa es el estado ESTK, mientras que la liga verdadera es el estado ESTI.



Figura Carta ASM para el direccionamiento por trayectoria.

		Dirección de Memoria			Contenido de Memoria					
Edo. Presente		Entradas			Liga		Salidas			
		Q <sub>1</sub>	Q <sub>2</sub>	Q <sub>3</sub>			S <sub>1</sub>	S <sub>2</sub>	S <sub>3</sub>	S <sub>4</sub>
EST0	0 0	0	0	0	0	0	1	0	0	0
	0 0	0	1	0	1	1	1	0	0	0
	0 0	0	1	1	1	1	1	0	0	0
	0 0	0	0	1	0	0	1	0	0	0
	0 0	1	0	0	0	1	1	0	0	0
	0 0	1	0	1	0	1	1	0	0	0
	0 0	1	1	0	0	1	1	0	0	0
	0 0	1	1	1	0	1	1	0	0	0
EST1	0 1	0	0	0	1	0	0	0	1	1
	0 1	0	0	1	0	0	0	1	0	1
	0 1	0	1	0	1	0	0	0	1	1
	0 1	0	1	1	0	0	0	1	0	1
	0 1	1	0	0	1	0	0	0	1	1
	0 1	1	0	1	0	0	0	1	0	1
	0 1	1	1	0	1	0	0	0	1	1
	0 1	1	1	1	0	0	0	1	0	1
EST2	1 0	0	0	0	0	0	0	1	1	0
	1 0	0	0	1	0	0	0	1	1	0
	1 0	0	1	0	0	0	0	1	1	0
	1 0	0	1	1	0	0	0	1	1	0
	1 0	1	0	0	0	0	0	1	1	0
	1 0	1	0	1	0	0	0	1	1	0
	1 0	1	1	0	0	0	0	1	1	0
	1 0	1	1	1	0	0	0	1	1	0
EST3	1 1	0	0	0	0	0	0	1	0	0
	1 1	0	0	1	0	0	0	1	0	0
	1 1	0	1	0	0	0	0	1	0	0
	1 1	0	1	1	0	0	0	1	0	0
	1 1	1	0	0	0	0	0	1	0	0
	1 1	1	0	1	0	0	0	1	0	0
	1 1	1	1	0	0	0	0	1	0	0
	1 1	1	1	1	0	0	0	1	0	0

La figura muestra una carta ASM la cual se construirá utilizando este método.

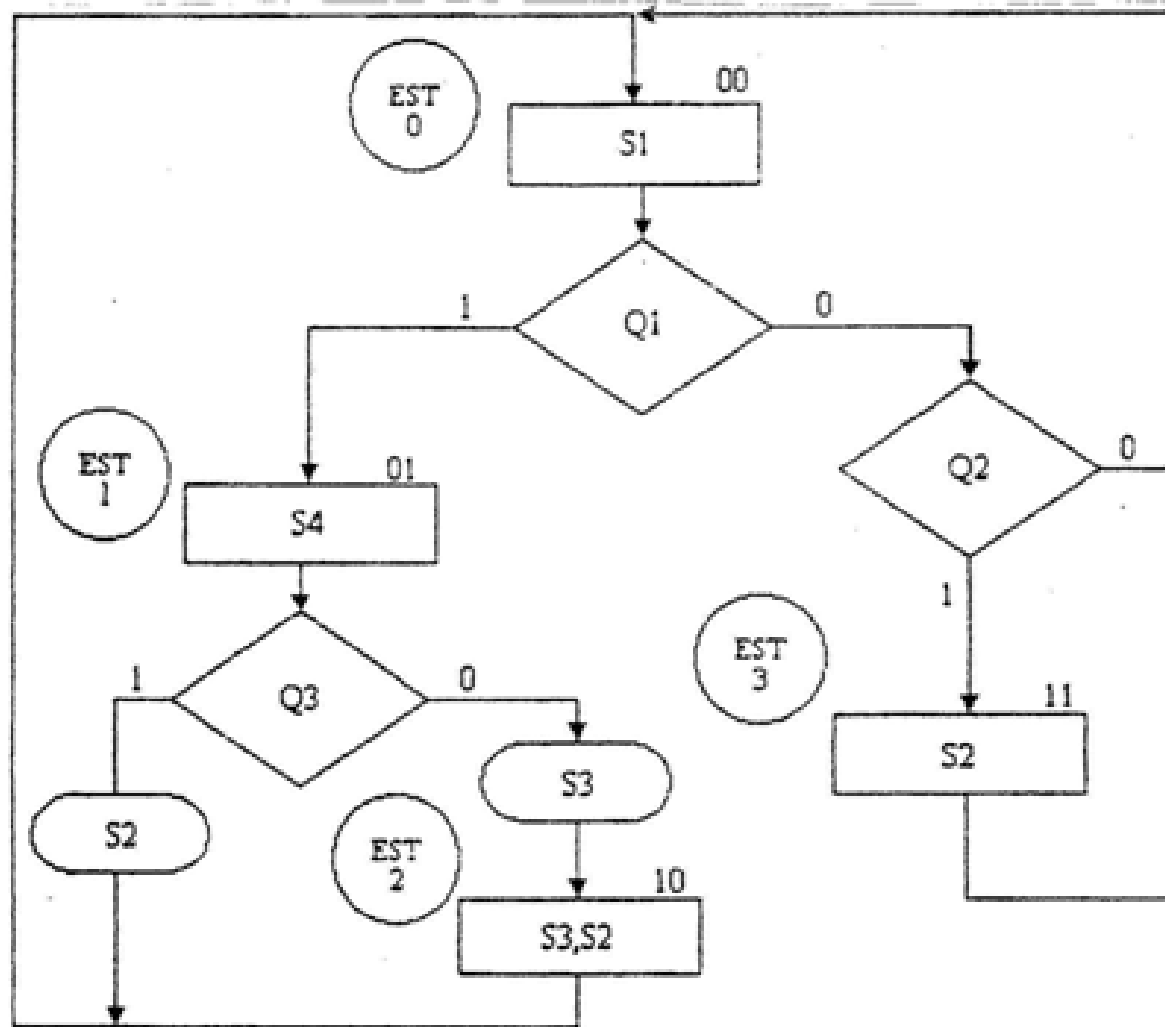
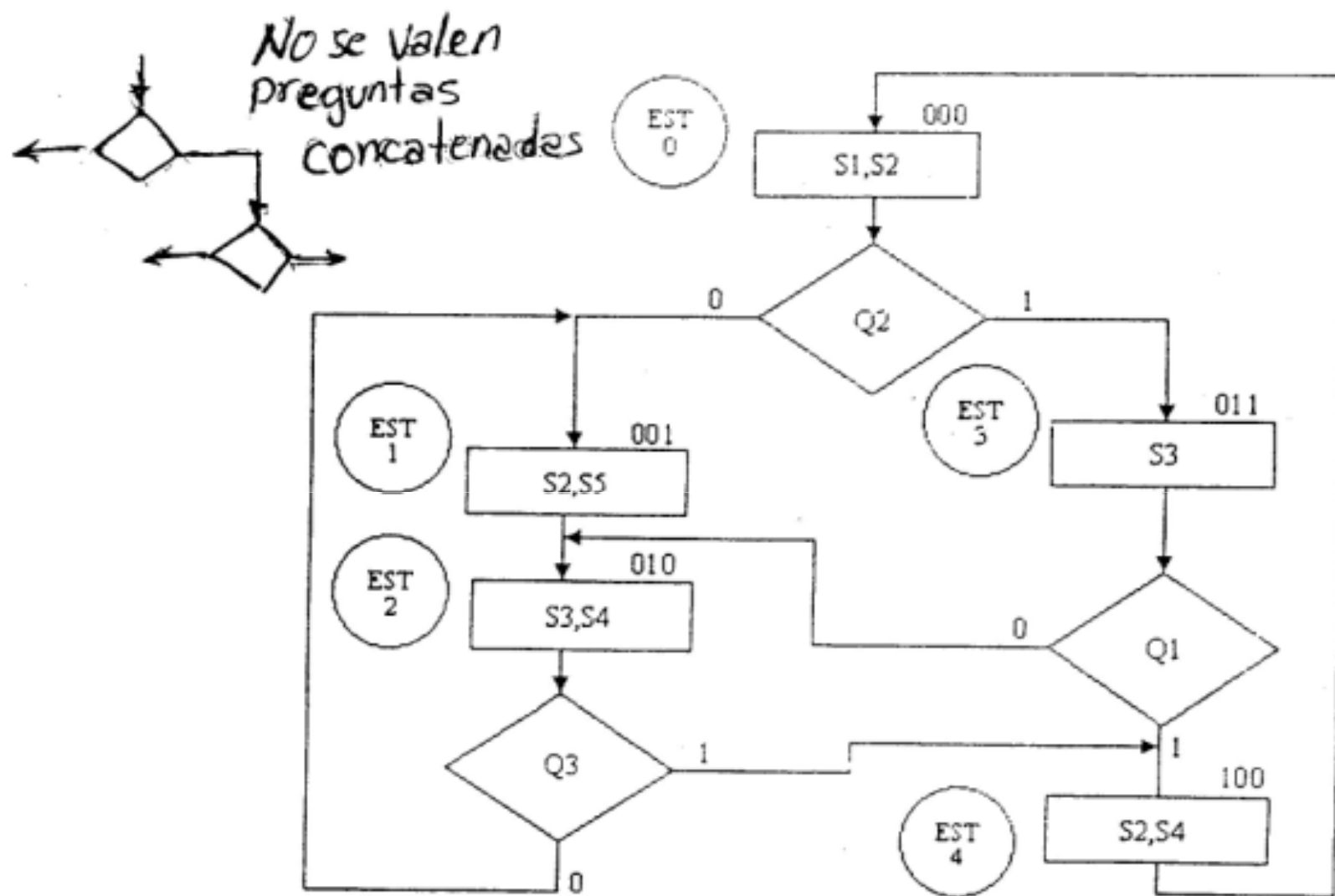

Carta ASM para el direccionamiento entrada-estado.